



Le spécialiste des équipements électroniques

Zac de la plaine - 1, rue Brindejont des Moulinais
31500 TOULOUSE
Tél : +33 (0)5 67 77 94 44 - Fax : +33 (0)5 67 77 94 49
info@pst-france.fr - www.pst-france.fr

OPTO-4

NMEA[®] 0183 PC Opto-Isolator Cable

Isolate an RS232 (PC) port to protect against ground loops

Introduction

The Actisense NMEA 0183 PC Opto-Isolator Cable (OPTO-4) is an easy way to link an NMEA 0183 device to an RS232 (PC) serial port. The OPTO-4 isolation ensures the connected PC (or any other device with a standard full RS232 9-pin port) meets the latest NMEA 0183 input specification

Features

- NMEA 0183 & RS232 compliant
- Full duplex (two-way) communication
- All baud rates up to 115200 Baud
- Overmoulded case with a narrow profile for installing in small spaces
- Transient protection on the PC output line
- Opto-isolation providing 2000 volt protection on the PC input line
- Reverse voltage protection on the PC input line
- Current limited to protect against cable faults
- Port-powered; takes power from the PC port
- Fully shielded for superior noise rejection

Connection Example

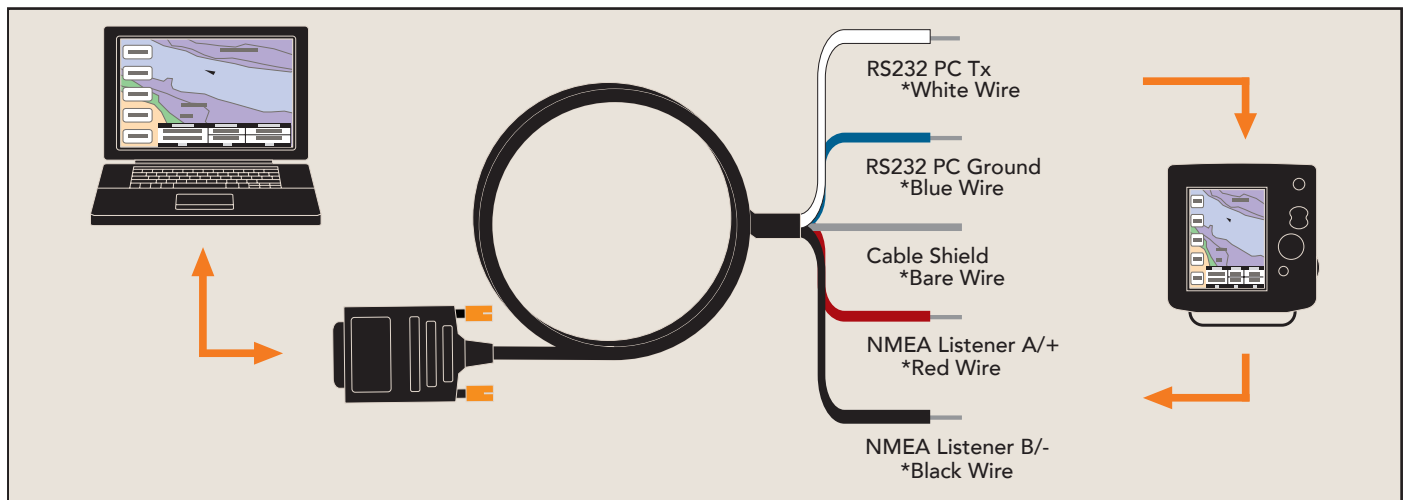

Dimensions

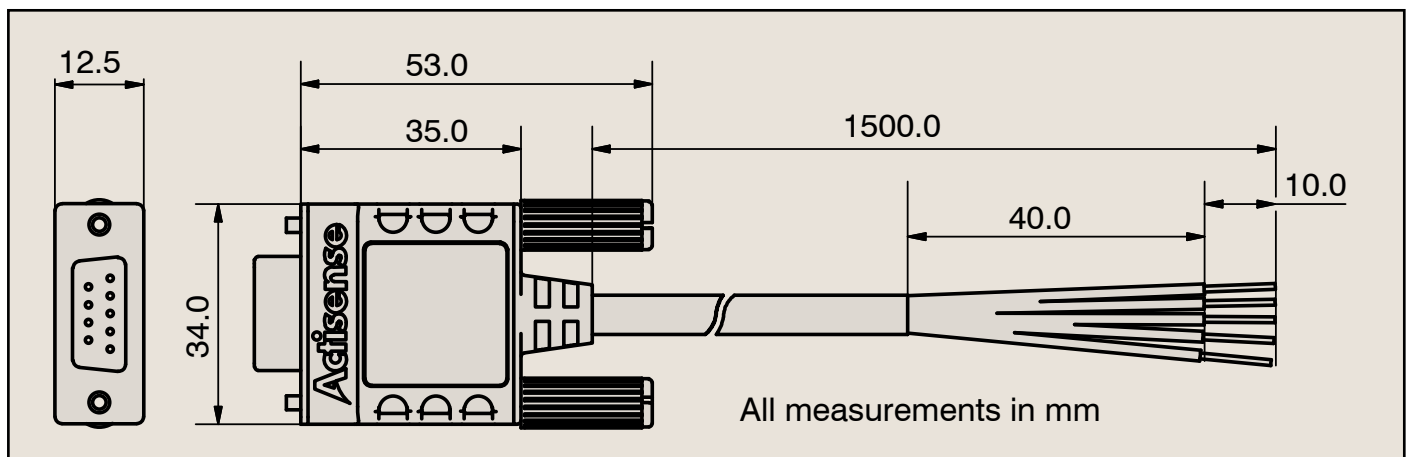

OPTO-4

NMEA® 0183 PC Opto-Isolator Cable

Technical Specifications

Electrical	
NMEA Listener / Input Isolation	2kV Opto-Isolation between Red / Black NMEA Input Pair and all other Connections
NMEA Listener / Input Voltage	+/-15V Continuous Maximum +/-35V Max < 1 Second
NMEA Listener / Input Signal Thresholds	Logic '0' +2V to +15V Logic '1' -15V to 0V
NMEA Talker / Output Voltage & Current	Dependant on Host RS232 Interface. Typically +/-5V to +/-15V @ 10mA Max
RS232 Voltage on Host	+/-7V to +/-15V
RS232 Port Total Current Consumption	2mA to 5mA depending on RS232 Voltage
Speed / Baud Rate	4800 to 115200 Baud
Mechanical	
Housing Material	PVC Black
Thumb Screw Material	PVC Orange
Screw	Steel, Nickel Plated, M2.8 Thread
DB9 Connector	9 Pin Female
Cable Length	1.5m
Cable Wire	22AWG (17/34AWG) Tinned Stranded Copper
Cable Jacket	PVC
Shield	Internal Copper Foil Shield
Cable Outer Diameter	5.5mm
Approvals and Certifications	
Operating Temperature	-20°C to +70°C
Electrical Specificatio	Meets IEC 61162-2
Weight	100g
Guarantee	3 Years
UL Certificatio	Cable E137250
RoHS Compliant	

DB9 Pin Out Table

DB9 Pin Number	Function
Pin 1	No Connection
Pin 2	PC Rx / OPTO-4 Tx
Pin 3	PC Tx / OPTO-4 Rx
Pin 4	PC DTR / OPTO-4 Power
Pin 5	GND
Pin 6	No Connection
Pin 7	PC RTS / OPTO-4 Power
Pin 8	No Connection
Pin 9	No Connection

Part Number	Description
OPTO-4	NMEA 0183 PC Opto-Isolator Cable, RS232 DB9 Female, Shielded (Isolated to PC)



Additional Information

The OPTO-4 takes power from the host RS232 signals including TX and the handshaking lines RTS and DTR, making the OPTO-4 suitable for most PC serial ports.

In systems that cannot provide power on the handshaking lines, e.g. serial devices with only Rx and Tx lines, a DC power supply can be used.

Note: Connecting an external power supply may create a ground loop between the PC port and the supply. Check that the supply ground is at the same potential as the PC ground before connecting.

Please refer to the Quick Start Guide for detailed wiring instructions, including how to use an external power supply.

NMEA 0183 Wiring Table

OPTO-4 Wire Colour	Function (connects to)
Red	OPTO-4 Listener Rx A/+ (Talker Tx A/+ or Data)
Black	OPTO-4 Listener Rx B/- (Talker Tx B/- or Ground)
Bare	Shield
White	OPTO-4 Talker Tx A/+ (Listener Rx A/+ or Data)
Blue	OPTO-4 Talker Tx B/- (Listener Rx B/-)